



# TBX Tower Series

- X Brace design for strength
- Braces riveted in center as well as ends
- All riveted construction
- Greater width and weight at bottom
- Beaded channel leg for added strength
- All steel
- Pregalvanized for added life
- Rotors easily installed
- Three steps included on one face of top section

Available From:

**Sandown Wireless**

E-mail: [sales@criticaltowers.com](mailto:sales@criticaltowers.com)

Office: 603-974-0725

[www.criticaltowers.com](http://www.criticaltowers.com)

Note: Contact by E-mail is preferred

Manufactured in the U.S.A.

# TBX Tower

Part #	8' TBX Sections	wt.
TBX1A	Offset top section w/TP1, RP1, MK2	26#
TBX2	Standard offset section	24#
TBX2A	Offset top section w/TP2, RP2, TC	31#
TBX3	Standard offset section	29#
TBX3A	Offset top section w/TP3, RP3, TC	39#
TBX4	Standard offset section	42#
TBX5	Standard offset section	60#
TBX6	Standard offset section	65#
TBX7	Standard offset section	75#
TBX8	Standard offset section	83#
TBX8ST	Standard offset straight section	85#

Nuts and bolts are included in section prices.

For TBX8ST, the top sets of braces are bolted to tower for ease of installation.

Part #	TBX Accessories	wt.
MK2	Mast hardware kit w/rotor post for top and rotor plate	2#
TC	Heavy duty mast clamp	3#
TB3	Heavy duty thrust bearing, recommended for 2" OD tubing (for use w/section 3 with field drilled hole)	2 ½#
TB4	Heavy duty thrust bearing, recommended for 3" OD tubing (for use w/section 3 with field drilled hole)	3#
SM	Side mount (28"- 40") w/4', 1 ¼ " OD mast (fits sections 1 thru 4)	12#
SK1	Extra step kit for section 1 (3 steps on one face)	1#
SK2	Extra step kit for section 2 (3 steps on one face)	1#
SK3	Extra step kit for section 3 (3 steps on one face)	1#
ACP	Anti climb panels	

Part #	Top and Rotor Plates	wt.
TP1A	Top plate for section 1 w/hardware nuts, bolts, and TACWS	2#
TP2A	Top plate for section 2 w/hardware nuts, bolts, and TACWS	2#
TP3A	Top plate for section 3 w/hardware nuts, bolts, and TACWS	2½#
RP1A	Rotor plate for section 1 w/hardware nuts, bolts, and TACWS	1½#
RP2A	Rotor plate for section 2 w/hardware nuts, bolts, and TACWS	2#
RP3A	Rotor plate for section 3 w/hardware nuts, bolts, and TACWS	2½#

Part #	Masts	wt.
P8114	8' mast (1 ¼")	6 ½#

## TBX Anti-Climb Panels

- Flat surface for extra security
- Made of durable 20ga steel
- Available for TBX, THBX and THDBX series



## ASSEMBLY INSTRUCTIONS

### BREAKING DOWN THE BUNDLE

1. Mast, accessories, and hardware packages need to be removed prior to de-bundling of the tower sections.
2. Bundle is to be laid on its side on a flat smooth surface.
3. Remove innermost section (*smallest*) by sliding from the bottom (*widest opening*). Proceed with each additional section. Protective gloves are suggested and the use of pry tools are not recommended.
4. Inspect each section for any transport, or shipping damage. It is acceptable to replace any broken, or lose rivets with a snug fitting machine bolt, nut, and lock washer. If replacing a rivet make sure the bolts are securely tightened.

### TOWER

After you have chosen the desired type of base for your tower (*concrete base with concrete base stubs, or hinged concrete base*) and it is properly installed per base instructions, bolt the base section (*the largest section*) to the base. Proceed with the erection as follows:

1. The legs on each higher section slide inside the previous one and should be positioned on the stop rivet in the previous leg. (*This stop rivet is to prevent the tower section being installed from slipping through the previous section and is not for the purpose of aligning the assembly holes.*) (*Special Note: the TBX8 section does not have a stop rivet in it, so extreme caution should be used when installing the TBX7 section into the TBX8 section.*) Proceed by bolting together each section with the proper size bolts.
2. To erect the tower, section by section vertically, insert the next proceeding section into the previous allowing the stop rivet to catch the section, and then install the appropriate section hardware. By using HB36 or HB78 base, the tower can be assembled on the ground and hinged up using extreme caution. When hinging up, watch for power lines, trees, etc.
3. Loose, missing or faulty rivets should be replaced with a similar size nut and bolt which can be obtained at any local hardware.

#### Note

3/8" bolts are used on TBX1, TBX2 and the top of the TBX3 sections. 9/16" bolts are used on the bottom of the TBX3 and all sections from TBX4 through TBX8 (*TBX8 is the largest section*).

One set of cross braces on one face of the top section is purposely left off to allow easy access to the rotor plate for installing the mast and rotor.

**Only one person should be on the tower at one time.**

## ROTOR INSTALLATION

Most all makes of rotors can be installed on the rotor plate inside the top tower section of the TBX standard, THBX, heavy duty, and THDBX extra heavy duty towers. There is a short piece of tubing furnished with each tower that can be used as a thrust bearing (for 1-1/4" mast) with the mast clamp installed on the top plate as is described under the heading Mast Assembly. Do not install rotors on the THDBX top plate.

For the THBX – Heavy Duty and THDBX - Extra Heavy Duty Towers, when a rotor is used a 4" piece of tubing or pipe with an I.D. larger than the O.D. of the mast can be installed in the pipe flange clamp and used as a bearing for the mast to turn in.

### FOR ASSEMBLING THE ROTOR ITSELF, FOLLOW THE PROCEDURES OUTLINED BELOW:

Some inline model rotors mount directly to the rotor plate. (The lower housing of the rotor is not used when this is done.) The necessary holes for mounting most rotors are pre-punched in the plate itself and the bolts furnished to bolt the lower housing to the upper housing (4-1/4" x 1" bolts) are to be inserted from the bottom of the plate upward and into the rotor. It is desirable to place 3/8" nuts to act as spacers between the rotor plate and the rotor.

These nuts will prevent the terminals of the rotor and the rotor wire from shorting on the rotor plate. An 8" piece of tubing is furnished with each tower. It can be installed into the clamp ("V" clamp and "L" shaped brackets furnished for offset rotor installation only) for the offset type rotors. It is necessary to reverse the clamp assembly (to face outside of the tower), opposite that of installing a standard mast to the rotor plate. Some rotors can be mounted directly to the "L" shaped bracket or to the 8' mast as previously described.

Also, some rotors mount beneath the rotor plate. It will be necessary to increase the 1/4" holes in the rotor plate to 3/8" holes to use the 3/8" bolts furnished with these rotors.

## MAST ASSEMBLY

1. Two U-bolt assemblies with "L" brackets are supplied for installing the mast. These "L" brackets are bolted through the slotted holes on the rotor and top plate with the short legs of the "L" bracket toward the outside of the tower.
2. Run the U-bolt through the open side of the formed "V" clamp and into the "L" bracket placing the 5/16" nuts and washers on the U-bolt loosely.
3. To install the mast, place one end of it through the upper U-bolt assembly end plate and slide it down into the lower U-bolt assembly to hold the mast.
4. Adjustments to make the mast vertical may be made by moving the "L" brackets in the slotted holes. The THBX – Heavy Duty and THDBX – Extra Heavy Duty Towers are furnished with a mast clamp installed on the top plate made from a pipe floor flange, which is provided with three bolts to be used as set screws to secure the mast. The box of hardware consists of one U-bolt assembly as described above and it can be installed on the lower plate as is instructed above, if required.

**In all cases be careful during installation.**

### Notes

- Do not install towers near power lines. All towers should be installed out of falling distance of power lines since every electrical and telephone wire should be considered dangerous.
- It is recommend that anti-climb sections should be installed on all towers to prevent unauthorized persons from climbing towers. Only one person should be on the tower at a time.
- All antenna installations must be grounded per local or national codes.
- All towers should be installed and dismantled by experienced and trained personnel.
- All types of antenna installations should be thoroughly inspected by qualified personnel at least twice a year and re-marked with hazard and warning labels to ensure safety and proper performance. A safety package (part number TACWS) is available which includes one anti-climb warning sign and two Danger – Watch for Wires labels along with other printed safety information.

Section #	LEG JOINT BOLTS			"X" (Top)	"Y" (Bottom)
	Location	Qty	Size		
2	Top	2	$\frac{3}{8} \times \frac{3}{4}$	10 $\frac{7}{16}$ "	12 $\frac{11}{16}$ "
	Bottom	2	$\frac{3}{8} \times \frac{3}{4}$		
3	Top	2	$\frac{3}{8} \times \frac{3}{4}$	12 $\frac{13}{16}$ "	15 $\frac{1}{16}$ "
	Bottom	2	$\frac{9}{16} \times 1$		
4	Top	2	$\frac{9}{16} \times 1$	15 $\frac{3}{16}$ "	17 $\frac{7}{16}$ "
	Bottom	2	$\frac{9}{16} \times 1$		
5	Top	2	$\frac{9}{16} \times 1$	17 $\frac{5}{8}$ "	20 $\frac{1}{8}$ "
	Bottom	2	$\frac{9}{16} \times 1$		
6	Top	2	$\frac{9}{16} \times 1$	20 $\frac{5}{16}$ "	22 $\frac{13}{16}$ "
	Bottom	2	$\frac{9}{16} \times 1$		
7	Top	2	$\frac{9}{16} \times 1$	23"	25 $\frac{1}{2}$ "
	Bottom	3	$\frac{9}{16} \times 1$		
8	Top	3	$\frac{9}{16} \times 1$	25 $\frac{11}{16}$ "	28 $\frac{7}{16}$ "
	Bottom	3	$\frac{9}{16} \times 1$		

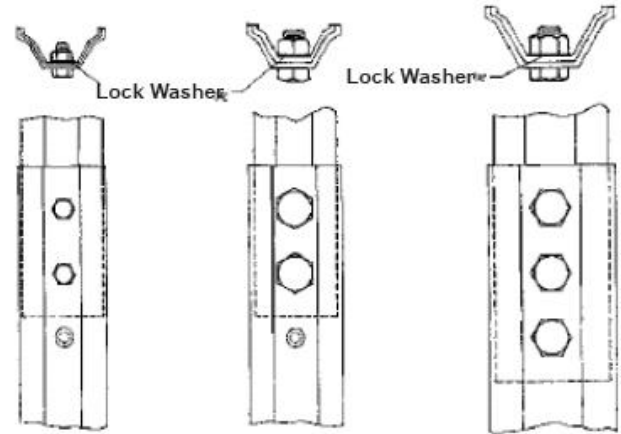
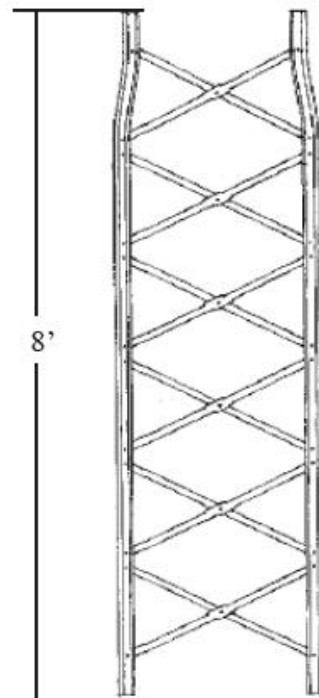
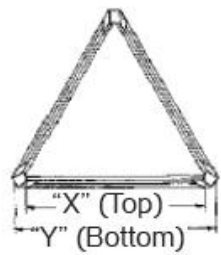
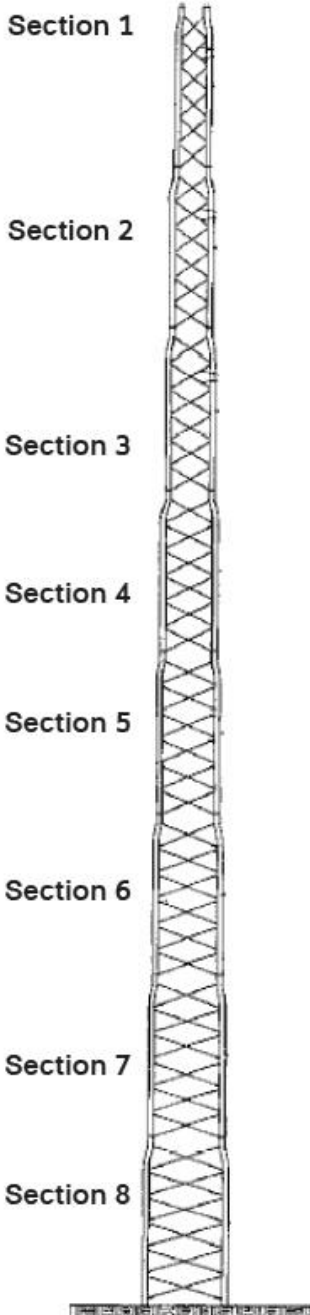

**Typical Leg Joint** between Sections 1-2 and Sections 2-3  
**Typical Leg Joint** between Sections 3-4, Sections 4-5, Sections 5-6, and Sections 6-7  
**Typical Leg Joint** between Sections 7-8

# HINGED BASE FOUNDATION

## Foundation Notes

1. Concrete, 3000 P.S.I. minimum ultimate strength.
2. ASTM A-615 Grade 40 deformed re-bars.
3. All forms must be removed from concrete before placing compacted backfill.
4. Foundations designed for 2000 PSF soil.
5. It is recommended that a wood template be constructed by the user for holding anchor bolts at the proper dimensions while concrete is being poured.
6. Reinforcing is recommended for temperature and shrinkage control.
7. Welding is prohibited on reinforcing steel and embedments.

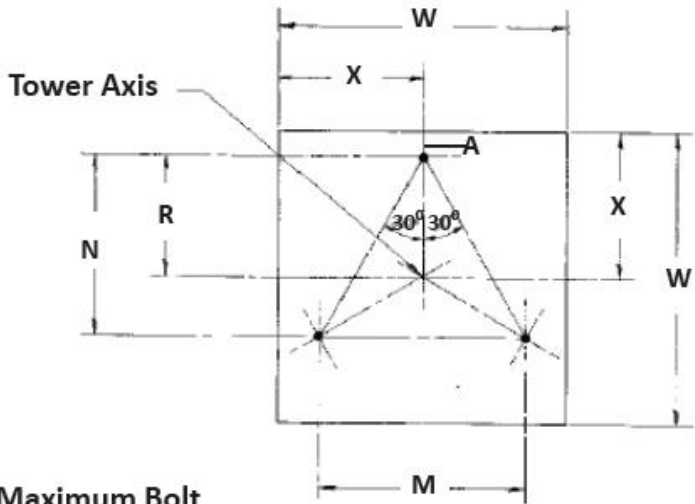

**Maximum Bolt Projection**  
(See Chart)

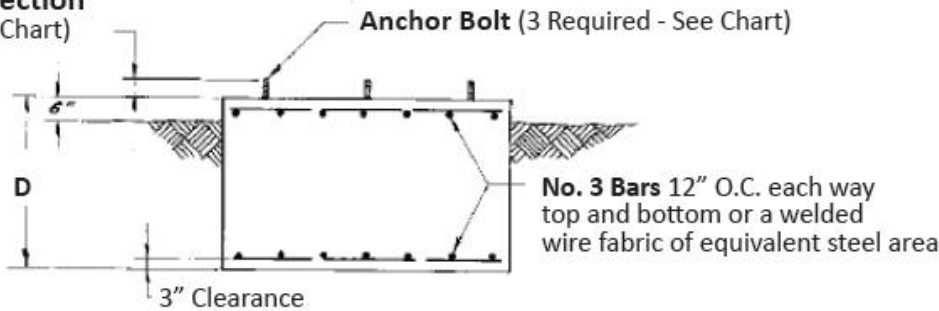

## HINGED BASE

Sec No.	M	N	R	Max. Proj.	Anchor Bolt	Bearing	D	W	X	CU. YDS. CONC.
3	13 <sup>5</sup> / <sub>16</sub> "	11 <sup>1</sup> / <sub>2</sub> "	7 <sup>11</sup> / <sub>16</sub> "	2 <sup>5</sup> / <sub>8</sub> "	(3) - <sup>3</sup> / <sub>4</sub> " x 20"	BP13	4' -0"	3'-6"	1'-9"	1.8
4	15 <sup>1</sup> / <sub>16</sub> "	13 <sup>5</sup> / <sub>16</sub> "	9 <sup>1</sup> / <sub>16</sub> "	2 <sup>5</sup> / <sub>8</sub> "	(3) - <sup>3</sup> / <sub>4</sub> " x 20"	BP13	4' -0"	4'-0"	2'-0"	2.4
5	18 <sup>5</sup> / <sub>16</sub> "	15 <sup>7</sup> / <sub>8</sub> "	10 <sup>9</sup> / <sub>16</sub> "	2 <sup>5</sup> / <sub>8</sub> "	(3) - <sup>3</sup> / <sub>4</sub> " x 20"	BP13	4' -0"	4'-6"	2'-3"	3.0
6	21"	18 <sup>3</sup> / <sub>16</sub> "	12 <sup>1</sup> / <sub>8</sub> "	2 <sup>5</sup> / <sub>8</sub> "	(3) - <sup>3</sup> / <sub>4</sub> " x 20"	BP13	4' -0"	4'-9"	2'-4 <sup>1</sup> / <sub>2</sub> "	3.4
7	23 <sup>1</sup> / <sub>4</sub> "	20 <sup>1</sup> / <sub>8</sub> "	13 <sup>3</sup> / <sub>16</sub> "	3 <sup>1</sup> / <sub>4</sub> "	(3) - 1" x 30"	BP14	4' -0"	5'-3"	2'-7 <sup>1</sup> / <sub>2</sub> "	4.1
8	26 <sup>3</sup> / <sub>16</sub> "	22 <sup>1</sup> / <sub>16</sub> "	15 <sup>1</sup> / <sub>8</sub> "	3 <sup>1</sup> / <sub>4</sub> "	(3) - 1" x 30"	BP14	4' -0"	5'-9"	2'-10 <sup>1</sup> / <sub>2</sub> "	4.9

HINGED BASE 36 (HB36)		
QTY	PART #	DESCRIPTION
1	HBC1	STUB PIPE 1 1/2" STD
1	HBL1	STUB PIPE 1 1/2" STD
1	HBR1	STUB PIPE 1 1/2" STD
3	HY1	YOKE
3	AB20	ANCHOR BOLT 3/4" X 20"
6	W34	3/4" SPLIT WASHER
6	B9163	9/16" X 3" BOLT
12	N34	3/4" HVY HEX NUT
12	N916	9/16" HEX NUT
3	BP13	3/8" X 3" X 3" BEARING PLATE
6	B91612	9/16" X 3 1/2" BOLT

HINGED BASE 78 (HB78)		
QTY	PART #	DESCRIPTION
1	HBC2	STUB PIPE 2" STD
1	HBL2	STUB PIPE 2" STD
1	HBR2	STUB PIPE 2" STD
3	HY2	YOKE
3	AB30	ANCHOR BOLT 1" X 30"
6	W1	1" SPLIT WASHER
9	B91612	9/16" X 3 1/2" BOLT
12	N1	1" HVY HEX NUT
15	N916	9/16" HEX NUT
3	BP14	3/8" X 3 1/2" X 3 1/2" BEARING PLATE
6	B9164	9/16" X 4" BOLT

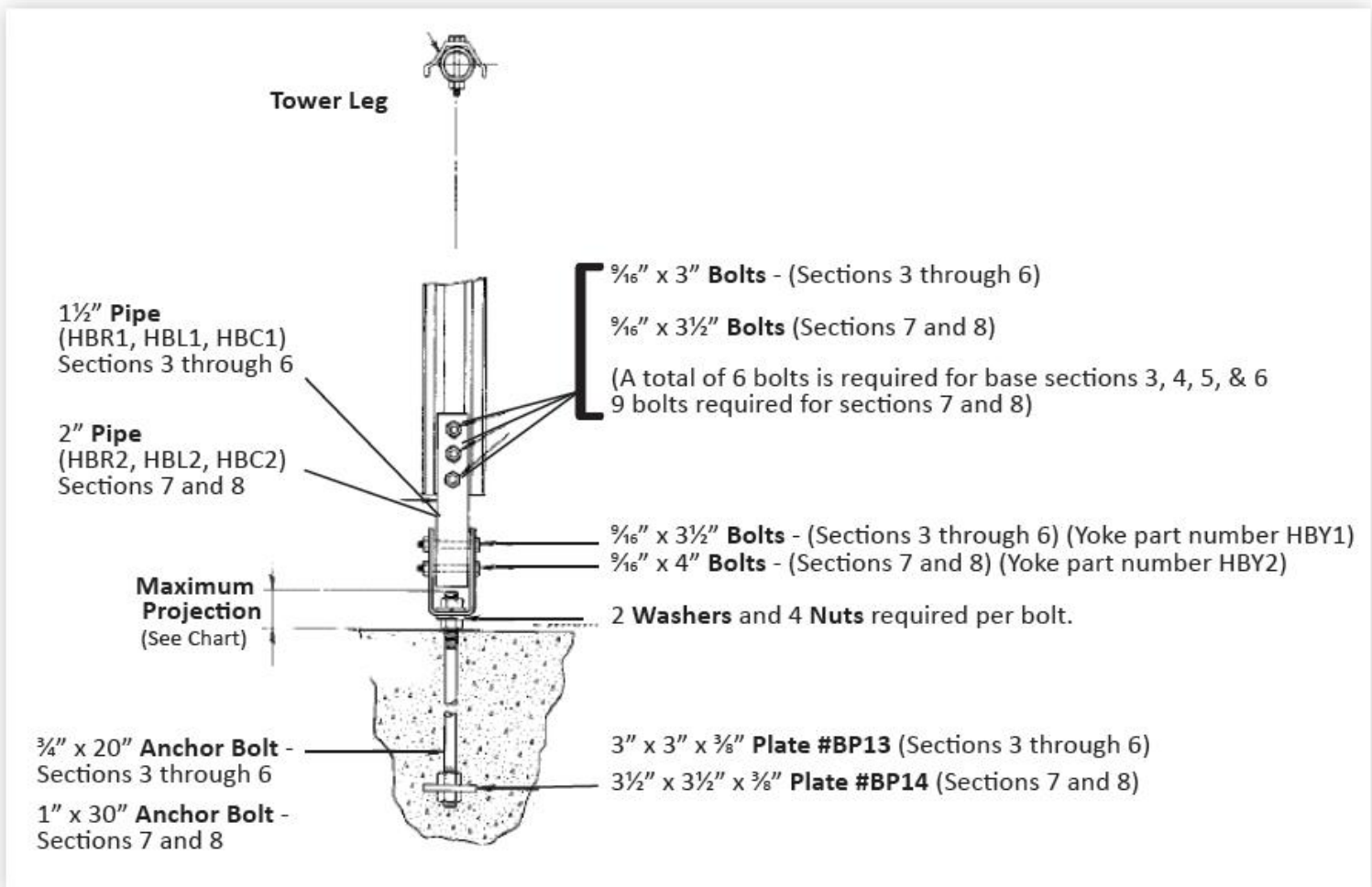

# BASE STUBS

## Foundation Notes

1. Concrete, 3000 PSI minimum ultimate strength.
2. ASTM A-615 Grade 40 deformed re-bars.
3. All forms must be removed from concrete before placing compacted backfill.
4. Reinforcing is recommended for temperature and shrinkage control.

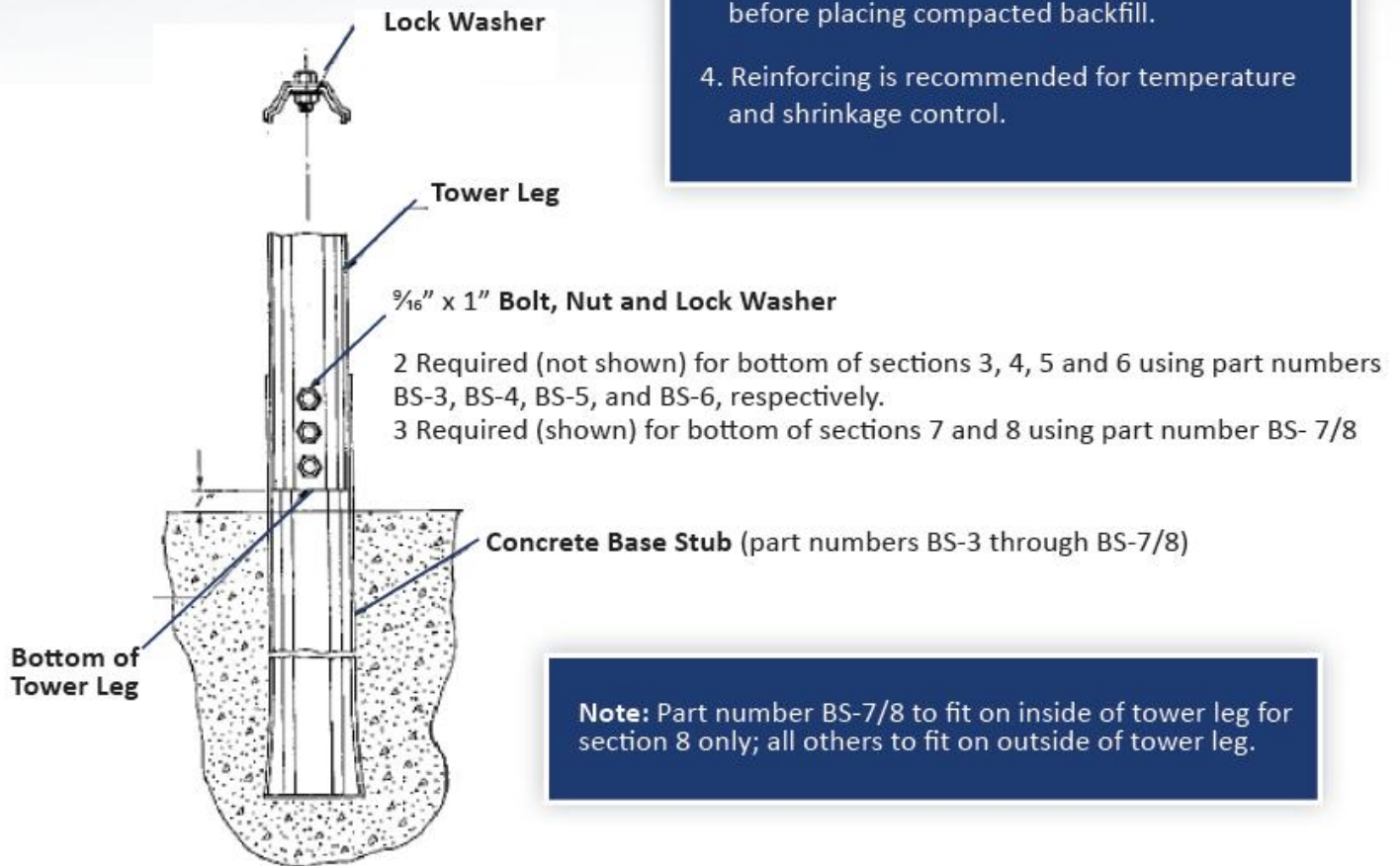

**Note:** Part number BS-7/8 to fit on inside of tower leg for section 8 only; all others to fit on outside of tower leg.

BASE STUB						
Part #	Sect. No.	W	X	D	Cu. Yds. Concr.	A
BS-3	3	3'-6"	1'-9"	4'-0"	1.8	1'-0 ¼"
BS-4	4	4'-0"	2'-0"	4'-0"	2.4	1'-2"
BS-5	5	4'-6"	2'-3"	4'-0"	3.0	1'-3 ½"
BS-6	6	4'-9"	2'-4 ½"	4'-0"	3.4	1'-3 ½"
BS-7/8	7	5'-3"	2'-7 ½"	4'-0"	4.1	1'-4 ¾"
BS-7/8	8	5'-9"	2'-10 ½"	4'-0"	4.9	1'-6"



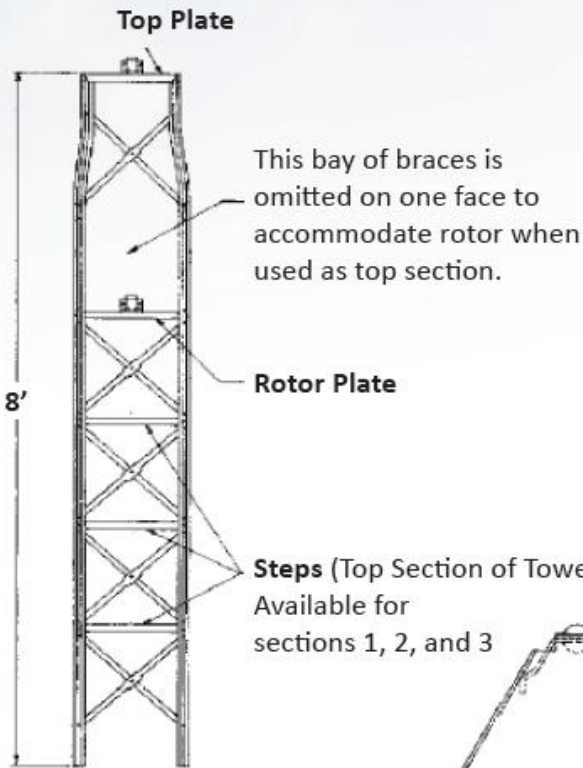

**Top Section (1, 2, or 3)**

For straight section eliminate 1/8" dimension.

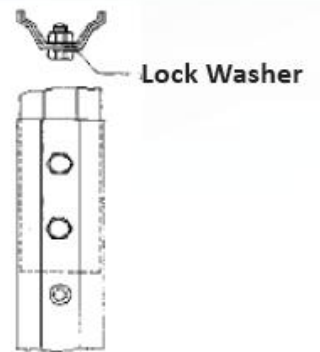
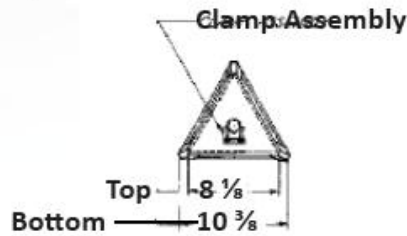

**Typical Leg Joint between Sections 1-2**

**Steps (Top Section of Tower)**  
Available for sections 1, 2, and 3

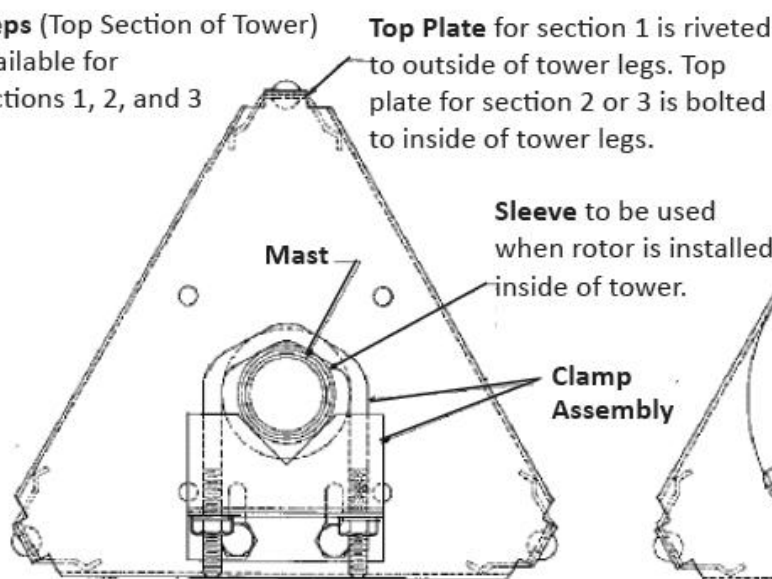

**Top Plate with Clamp Assembly**

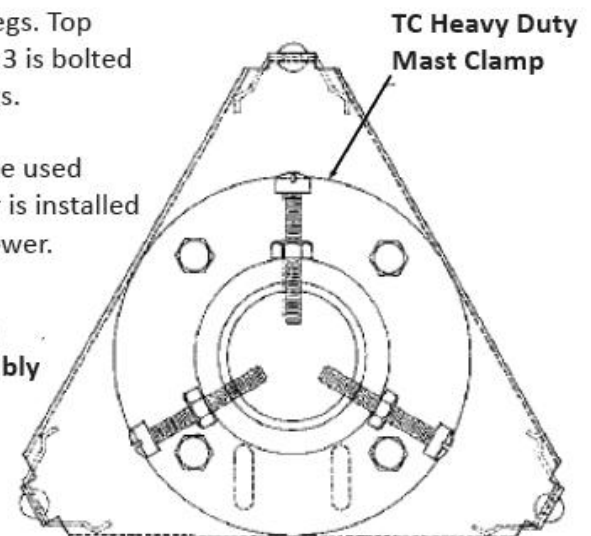

**Top Plate with TC Heavy Duty Mast Clamp.**

**Lower Mast Clamp** assembly not used for in-line model rotor when mounted directly to rotor plate.

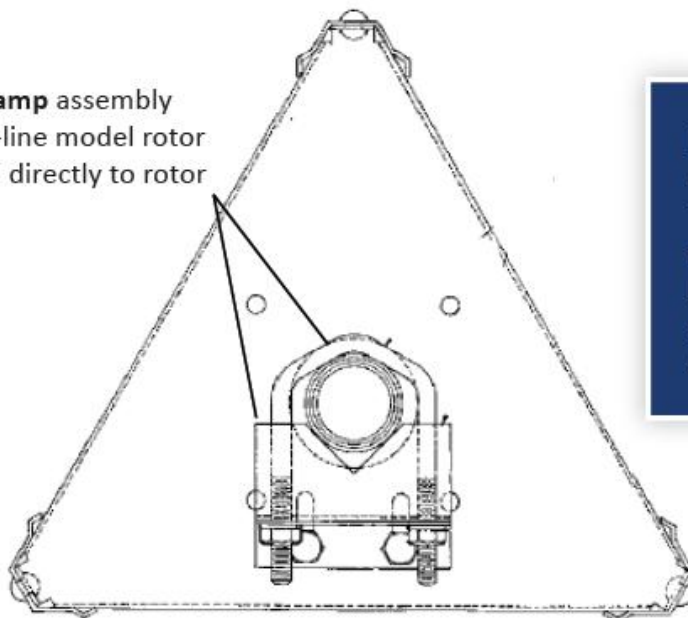

**Rotor Plate with Clamp**

**Note:** The clamp assembly is normally used with section 1 as a top section. The TC heavy duty mast clamp is normally used with section 2 or 3 as a top section. Holes are placed on all top plates and rotor plates, however, to accommodate either one.

# SIDE MOUNT

**Note:** For mounting on sections 1 thru 4

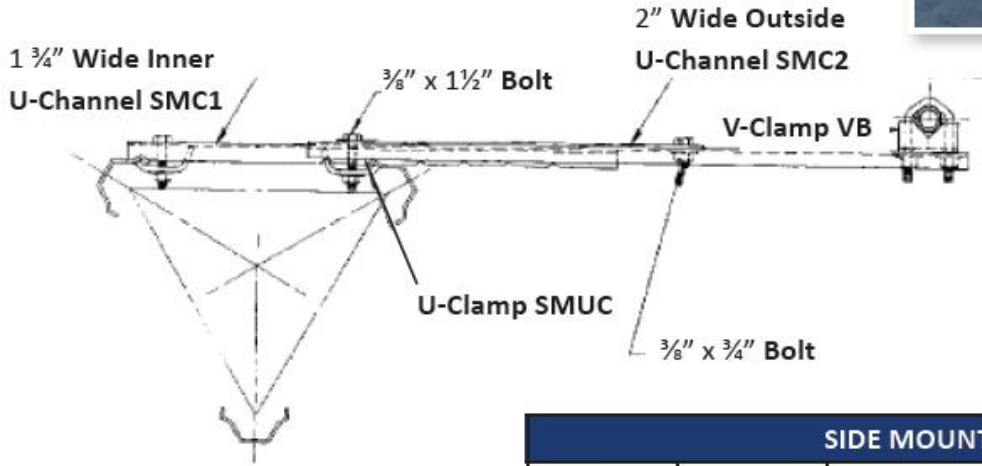
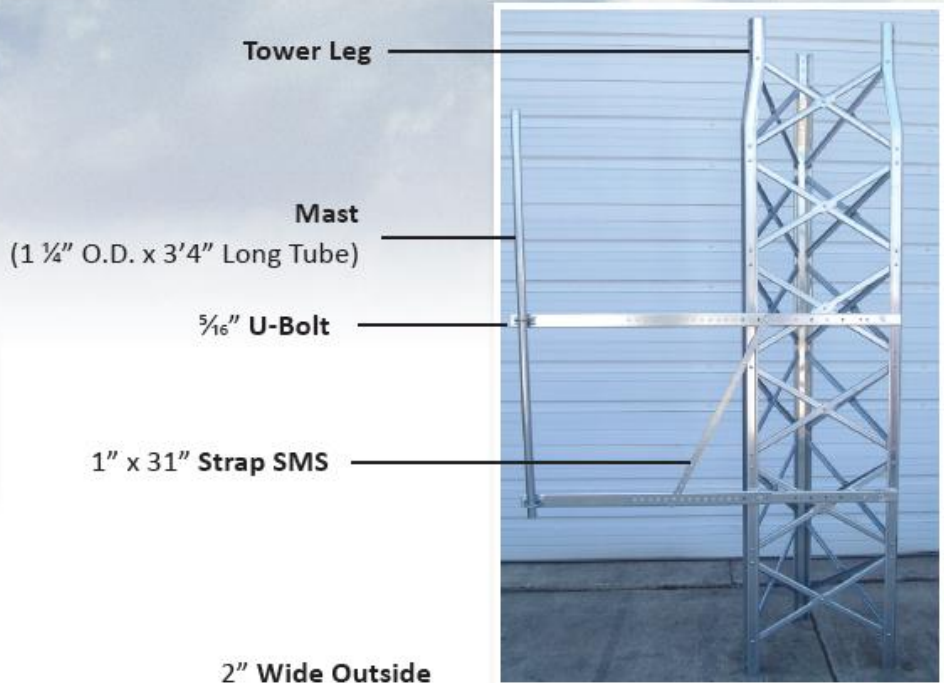

SIDE MOUNT (SM)		
QTY	PART #	DESCRIPTION
2	SMC2	2" WIDE OUTSIDE CHANNEL
2	SMC1	1 3/4" WIDE INNER CHANNEL
4	SMUC	U-CLAMP
1	SMS	1" X 31" STRAP
1	P11434	1 1/4" O.D. x 16 GA TUBE 3' 4" LONG
4	B38112	3/8" X 1 1/2" BOLT
5	N38	3/8" NUT
1	B38	3/8" X 3/4" BOLT
5	W38	3/8" WASHER
2	VB516	5/16" U-BOLT
4	N516	5/16" NUT
4	W516	5/16" WASHER
2	VB	V-BRACKET

TOWER MODELS		
Nominal Height, FT.	Catalog No.	Combination of Tower Sections
24	TBX24	TBX-1A-2-3
	THBX24	TBX-2A-3-4
	THDBX24	TBX-3A-4-5
32	TBX32	TBX-1A-2-3-4
	THBX32	TBX-2A-3-4-5
	THDBX32	TBX-3A-4-5-6
40	TBX40	TBX-1A-2-3-4-5
	THBX40	TBX-2A-3-4-5-6
	THDBX40	TBX-3A-4-5-6-7
48	TBX48	TBX-1A-2-3-4-5-6
	THBX48	TBX-2A-3-4-5-6-7
	THDBX48	TBX-3A-4-5-6-7-8
56	TBX56	TBX-1A-2-3-4-5-6-7
	THBX56	TBX-2A-3-4-5-6-7-8
64	TBX64	TBX-1A-2-3-4-5-6-7-8

TOWER OPTIONS (can be ordered separately)												
Tower Model	Concrete Base Stubs	Hinged Base	Side Arm Mt	Hardware Mast Kit	Rotor Plate	Top Plate	Extra Step Kit	Hardware Pack	Anti-Climb Panels	TBX5ST 8' Straight Section	TBX8ST 8' Straight Section	
TBX	24	BS-3	HB36	SM	MK2	RP1	TP1	SK1,2,3	HWP-TBX24	ACP3-3		
	32	BS-4	HB36	SM	MK2	RP1	TP1	SK1,2,3	HWP-TBX32	ACP3-4		
	40	BS-5	HB36	SM	MK2	RP1	TP1	SK1,2,3	HWP-TBX40	ACP3-5	TBX5ST	
	48	BS-6	HB36	SM	MK2	RP1	TP1	SK1,2,3	HWP-TBX48	ACP3-6		
	56	BS-7/8	HB78	SM	MK2	RP1	TP1	SK1,2,3	HWP-TBX56	ACP3-7		
	64	BS-7/8	HB78	SM	MK2	RP1	TP1	SK1,2,3	HWP-TBX64	ACP3-8		TBX8ST
THBX	24	BS-4	HB36	SM	MK2	RP2	TP2	SK2 & 3	HWP-THBX24	ACP3-4		
	32	BS-5	HB36	SM	MK2	RP2	TP2	SK2 & 3	HWP-THBX32	ACP3-5	TBX5ST	
	40	BS-6	HB36	SM	MK2	RP2	TP2	SK2 & 3	HWP-THBX40	ACP3-6		
	48	BS-7/8	HB78	SM	MK2	RP2	TP2	SK2 & 3	HWP-THBX48	ACP3-7		
	56	BS-7/8	HB78	SM	MK2	RP2	TP2	SK2 & 3	HWP-THBX56	ACP3-8		TBX8ST
THDBX	24	BS-5	HB36	SM	MK2	RP3	TP3	SK3	HWP-THDBX24	ACP3-5	TBX5ST	
	32	BS-6	HB36	SM	MK2	RP3	TP3	SK3	HWP-THDBX32	ACP3-6		
	40	BS-7/8	HB78	SM	MK2	RP3	TP3	SK3	HWP-THDBX40	ACP3-7		
	48	BS-7/8	HB78	SM	MK2	RP3	TP3	SK3	HWP-THDBX48	ACP3-8		TBX8ST

When purchasing a tower kit the rotor plate, top plate, hardware pack and one face of steps on top section are included. Leg Hardware is included with each section purchased.



Manufactured in the U.S.A.

Available From:

**Sandown Wireless**

E-mail: [sales@criticaltowers.com](mailto:sales@criticaltowers.com)

Office: 603-974-0725

[www.criticaltowers.com](http://www.criticaltowers.com)